



PROTECTION FROM ABOVE

ENHANCED SAFETY AGAINST VIRUSES, BACTERIA & MOLD

This location has certified
CLEAN AIRE

GUV-UVC DISINFECTION
FDA & EPA approved



*blue indicator light shows GUV system is active

UVC 8" Round Recessed Downlight w/ Integral J-box

EP-SADL-IJB Series | Ambient Lighting with Internal UVC Technology**

PRODUCT FACTS



ENHANCED AIRBORNE PATHOGEN DEFENSE SYSTEM AIR TREATMENT UV SOLUTIONS

KEY PRODUCT FEATURES, DETAILS & SPECS

- Engineered with the latest in UVC technology to inactivate bacteria & viruses
- Integral fan system draws in ambient air to help continuously facilitate air treatment
- A sealed internal UVC LED chamber ensures zero direct UVC exposure
- Improve air quality for use while the space is occupied (with no special controls, safety measures or training req'd)
- Blue indicator light lets you know that the GUV system is operational
- Blue Halo's fan system returns the treated air back into the space
- Cleanable filter is removable tool-free for ease of routine maintenance as required
- Ambient LED performance equal to 29.5W @ 2,500 lumens(35W system wattage)
- Ambient LED up to 85 LPW provides 60+% in energy savings vs. legacy downlight luminaires
- Installs like any recessed downlight, no special installation steps required, simply 'plug & play'

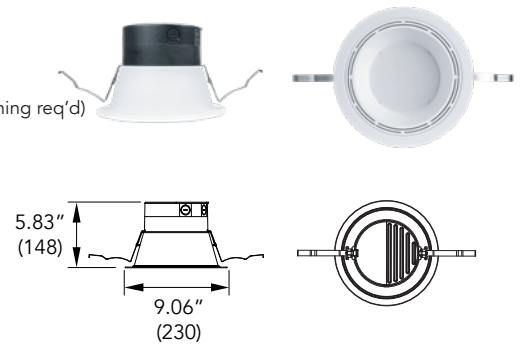

STOCK ORDERING INFORMATION (typical 2-3 day shipment lead time)¹

Catalog Logic/PT#	Model #	UPC	Size	Lumens	LED Watts	LPW	System Watts	CCT	CRI	Voltage	Dimming
EP-SADL-IJB-R8-2500LM-8-35K-MV-LVD	558021410	849489066738	8" Round	2,500	29.5	85	35.0	3500K	80 (min)	120-277V	0-10V

Notes:
1. In-stock inventory, specs subject to change (contact factory for availability).



UVC 8" Round Recessed Downlight

w/ Integral J-box

EP-SADL-IJB Series | Ambient Lighting with Internal UVC Technology**



AVAILABLE STOCK ACCESSORIES (must be ordered separately)



Additional Performance Accessories (requires field installation)

Catalog Logic/PT#	Model #	Description
EMA40FY-170 ¹ (G3)	70114402-2	Square, 40W, IP rated, 90 minutes

Notes:

1. BBUs certified in CA Title 20 MAEDBS. (search by Catalog logic/PT#, Ex. 'EMA40FY-170')

MISCELLANEOUS PRODUCT SPECS & DETAILS

Load Information

Power Factor	> 0.90
THD	< 25%
Frequency	50/60 Hz
Sound Rating	30-40 dBA
Low Temp LED	-20° C (-4° F)
Max Temp LED	45° C (113° F)
Low Temp UVC LED	-30° C (-22° F)
Low Temp Fan	-10° C (14° F)
Unit Weight	1.76 lbs

Lumen Maintenance

Ambient Temp	TM-21 LM Maintenance (54,000 hours)
25° C (77° F)	> 81.02%
Ambient Temp	TM-21 Theoretical (L70 hours)
25° C (77° F)	90,400

UV & FAN SPECIFICATIONS & DETAILS

UV Source	UV Wavelength	UV Irradiance	UV Wattage	UV Lifetime	Air Flow Rate	Fan Sound Rating	Fan Wattage	Fan Lifetime
LED	270-280nm	200 mW	4.0	30,000 hours	4CFM	30-40 dBA	1.5	50,000 hours

SYSTEM OVERVIEW

The SADL-IJB UVC 8" Round Recessed Downlight is a hybrid lighting solution that combines traditional LED ambient illumination with Blue Halo's internal air treatment system that does not allow any direct exposure to UVC. No specialized controls, safety measures or training required. All Blue Halo products can improve air quality when in use and the space is occupied vs. direct UVC solutions that can be a health and safety risk if not properly operated.

Blue Halo products are engineered with an integral quiet fan system designed to continuously funnel contaminated ambient air through an internally sealed UVC chamber. UVC technology is proven to effectively kill or inactivate many types of bacteria, mold, fungi and viruses. The system then returns treated air back into the occupied space.

Simply install SADL-IJB products like any traditional recessed downlight luminaire with 'plug & play' operation to help create safer people spaces against airborne pathogens. Pair with additional Blue Halo Lighting solutions to build an enhanced defense system against current and future bacteria.

UV AIR TREATMENT**



1. Integral fan & the space's HVAC system helps to funnel in contaminated ambient air
2. Fully enclosed UVC chamber kills or inactivates bacteria & viruses
3. Treated air is returned to the space, helping to increase air changes per hour

UV LED SPECTRUM DETAILS

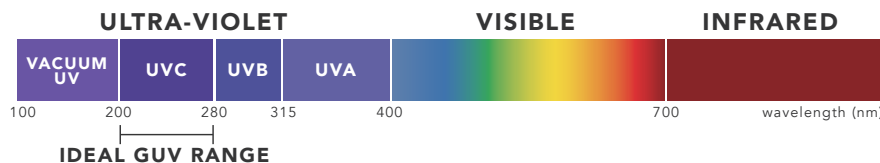

- GUV (Germicidal Ultraviolet) is an effective and proven technology in use for over 35-years
- The short ultraviolet wavelengths in the photobiological band "UVC" is ideal in eliminating bacteria
- The UVC range is outside the visible spectrum of "light" that can quickly kill bacteria & inactivates viruses
- Thanks to its fast efficacy, GUV within the UVC range is great for air treatment
- The effectiveness is set by the exposure dosage in irradiance & time (how much & how long)
- Direct exposure to GUV within the UVC range can be a safety & health hazard to both the skin & eyes
- Blue Halo sealed UVC chamber eliminates direct exposure when in use

SADL-DMJ Series UVC LED Spectrum

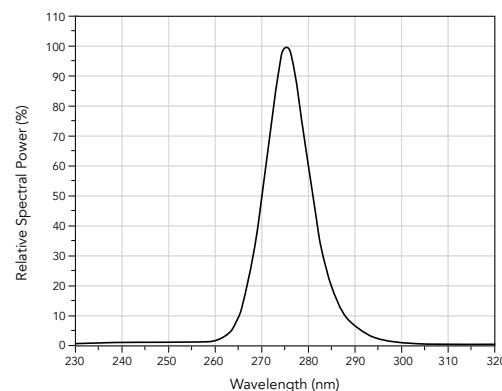

All specs are subject to change w/o notice & all reported values are nominal/typical measured under lab conditions @ 25° C (77° F).

**All references to "disinfection" are referring to the general reduction or inactivation of potential pathogens within a space.

**ETI SSL and its parent company does not promise/warrant the use of Blue Halo products will protect or prevent any end user from contamination and/or infection by any bacteria, mold, fungi, virus, illness or disease.