

PROTECTION FROM ABOVE

ENHANCED SAFETY AGAINST VIRUSES, BACTERIA & MOLD

This location has certified
CLEAN AIR

GUV-UVC DISINFECTION
FDA & EPA approved



UVC 6" Round Direct Mount
5-CCT ColorPreference® Canless Downlight w/ Remote J-box
EP-SADL-DMRJ Series | Ambient Lighting with Internal UVC Technology**

*blue indicator light shows GUV system is active

PRODUCT FACTS



ENHANCED AIRBORNE PATHOGEN DEFENSE SYSTEM
AIR TREATMENT UV SOLUTIONS

KEY PRODUCT FEATURES, DETAILS & SPECS

- Engineered with the latest in UVC technology to inactivate bacteria & viruses
- Integral fan system draws in ambient air to help continuously facilitate air treatment
- A sealed internal UVC LED chamber ensures zero direct UVC exposure
- Can improve air quality for use while the space is occupied (with no special controls, safety measures or training req'd)
- Blue indicator light lets you know that the GUV system is operational
- Blue Halo fan system returns the UVC treated & disinfected air back into the space
- Ambient LED 4000K performance equal to 10.5W @ 900 lumens(15.5W system wattage)
- Ambient LED up to 85 LPW provides 60+% in energy savings vs. legacy downlight luminaires
- Installs like any direct mount downlight, no special installation steps required, simply 'plug & play'
- ColorPreference® field selectable 5-CCT for added design flexibility (2700K, 3000K, 3500K, 4000K & 5000K)

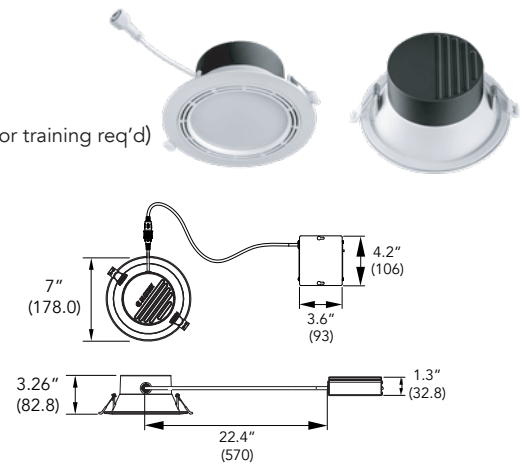

STOCK ORDERING INFORMATION (typical 2-3 day shipment lead time)^{1,2}

Catalog Logic/PT#	Model #	UPC	Size	Lumens ³	LED Watts	LPW	System Watts	CCT ⁴	CRI	Voltage	Dimming
EP-SADL-DMRJ-R6-900LM-9-5CP-SV-TR	558031010	849489066721	6" Round	900	10.5	85	15.5	5-CCT	80 (min)	120V	Triac

Notes:

1. In-stock inventory, specs subject to change (contact factory).
2. Lumen value & LPW shown is for 4000K ColorPreference® setting.
3. ColorPreference® field selectable 5-CCT (2700K, 3000K, 3500K, 4000K & 5000K).



UVC 6" Round Direct Mount

5-CCT ColorPreference® Canless Downlight w/ Remote J-box

EP-SADL-DMRJ Series | Ambient Lighting with Internal UVC Technology**



AVAILABLE STOCK ACCESSORIES (must be ordered separately)



Additional Performance Accessories (requires field installation)

Catalog Logic/PT#	Model #	Description
EMA25FY-170 ¹ (G3)	70112202-2	Square, 25W, IP rated, 90 minutes
LPGP-6IN	70313101	6" round rough-in guide plate
SADL-DMRJ-12FT-EXT	906008530	12' low voltage, IP65 extension cord
SADL-DMRJ-20FT-EXT	906008520	20' low voltage, IP65 extension cord

Notes:
1. BBU's certified in CA Title 20 MAEDBS. (search by Catalog Logic/PT#, Ex. 'EMA25FY-170')

MISCELLANEOUS PRODUCT SPECS & DETAILS

Load Information

Power Factor	> 0.90
THD	< 25%
Frequency	50/60 Hz
Sound Rating	30-40 dBA
Low Temp LED	-20° C (-4° F)
Max Temp LED	45° C (113° F)
Low Temp UVC LED	-30° C (-22° F)
Low Temp Fan	-10° C (14° F)
Unit Weight	1.5 lbs

Lumen Maintenance

Ambient Temp	TM-21 LM Maintenance (54,000 hours)
25° C (77° F)	> 80.12%
Ambient Temp	TM-21 Theoretical (L70 hours)
25° C (77° F)	86,240

GERMICIDAL UV & FAN SPECIFICATIONS & DETAILS

UV Source	UV Wavelength	UV Irradiance	UV Wattage	UV Lifetime	Air Flow Rate	Fan Sound Rating	Fan Wattage	Fan Lifetime
LED	270-280nm	200 mW	4.0	30,000 hours	3 CFM	30-40 dBA	1	50,000 hours

SYSTEM OVERVIEW

The SADL-DMRJ UVC 6" Round Direct Mount Canless Downlight is a hybrid lighting solution that combines traditional LED ambient illumination with Blue Halo's internal air treatment system that does not allow any direct exposure to UVC. No specialized controls, safety measures or training required. All Blue Halo products can improve air quality when in use and the space is occupied vs. direct UVC solutions that can be a health and safety risk if not properly operated.

Blue Halo products are engineered with an integral quiet fan system designed to continuously funnel contaminated ambient air through an internally sealed UVC chamber. UVC technology is proven to effectively kill or inactivate many types of bacteria, mold, fungi and viruses. The system then returns treated air back into the occupied space.

Simply install SADL-DMRJ products like any traditional canless direct mount downlight luminaire with 'plug & play' operation to help create safer people spaces against airborne pathogens. Pair with additional Blue Halo Lighting solutions to build an enhanced defense system against current and future bacteria.

UV AIR TREATMENT**

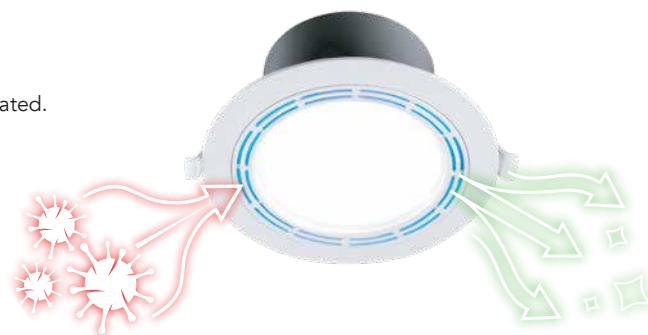

1. Integral fan & the space's HVAC system helps to funnel in contaminated ambient air
2. Fully enclosed UVC chamber kills or inactivates bacteria & viruses
3. Treated air is returned to the space, helping to increase air changes per hour

UV LED SPECTRUM DETAILS

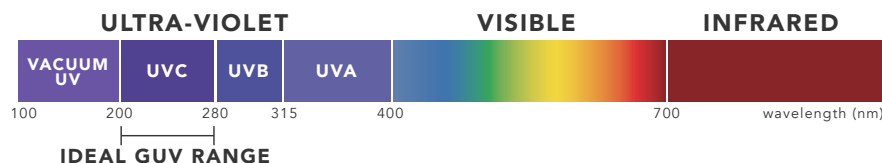

- GUV (Germicidal Ultraviolet) is an effective and proven technology in use for over 35-years
- The short ultraviolet wavelengths in the photobiological band "UVC" is ideal in eliminating bacteria
- The UVC range is outside the visible spectrum of "light" that can quickly kill bacteria & inactivates viruses
- Thanks to its fast efficacy, GUV within the UVC range is great for air treatment
- The effectiveness is set by the exposure dosage in irradiance & time (how much & how long)
- Direct exposure to GUV within the UVC range can be a safety & health hazard to both the skin & eyes
- Blue Halo's sealed UVC chamber eliminates direct exposure when in use

SADL-DMRJ Series UVC LED Spectrum

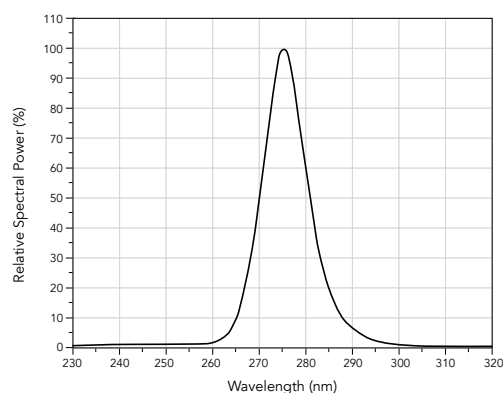

All specs are subject to change w/o notice & all reported values are nominal/typical measured under lab conditions @ 25° C (77° F).
**All references to "disinfection" are referring to the general reduction or inactivation of potential pathogens within a space.
**ETI SSL and its parent company does not promise/warrant the use of Blue Halo products will protect or prevent any end user from contamination and/or infection by any bacteria, mold, fungi, virus, illness or disease.