



\*\*shown w/ optional jelly jar field installed (must be ordered separately)

# Plasma Universal Flushmount Remote Universal Piggy-Back Disinfection System

EP-SAFM-PB Series I Universal Luminaire Plasma Air Disinfection\*\* Module

\*blue indicator light shows Plasma disinfection system is active

## GERMICIDAL PRODUCT FACTS



ENHANCED AIRBORNE PATHOGEN DEFENSE SYSTEM

**100% PEOPLE SAFE** GERMICIDAL PLASMA SOLUTIONS

## KEY PRODUCT FEATURES, DETAILS & SPECS

- Innovative piggy-back design turns any compatible flushmount luminaire into a Plasma System
- Works with most ETi SSL flushmount luminaires that installs to 3.5" & 4" j-boxes (or other compatible product)
- Can also be used and installed as a standalone Plasma device without a compatible luminaire
- Engineered with Blue Halo's 2nd Generation Plasma Technology to safely inactivate bacteria, mold & viruses
- Internal circulation system pushes and disperses plasma from the plasma generator
- Nonthermal "cold" plasma is generated internally via our Patent Pending Proprietary Technology
- 100% safe for use while the space is occupied (with no special controls, safety measures or training req'd)
- Blue indicator light lets you know that the Plasma disinfection system is operational
- Plasma technology continually and proactively treats the air in the occupied space at the source of contamination
- Installs like any LED flushmount, no special installation steps required, simply 'plug & play'

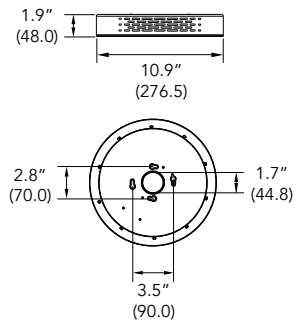

\*Preliminary image shown, sizing will stay roughly the same

## STOCK ORDERING INFORMATION (typical 2-3 day shipment lead time)<sup>1,2,3,4</sup>

Catalog Logic/PT#	Model #	UPC	Fan Wattage	System Watts <sup>5</sup>	Voltage	Finish
EP-SAFM-PB-R12-MV-GR	558081000	849489067483	6.0	See Below	120-277V	Black

Notes:

1. Stock SKUs typically ship in 24-48 hours upon receipt of an approved released order.
2. Specifier and/or installing contractor is responsible for confirming non-ETi SSL flushmount compatibility as needed.
3. Max compatible flushmount luminaire weight when installed to Model #558081000 is not to exceed 8.8 lbs.
4. Compatible ETi SSL luminaire must be ordered separately or can be installed as a standalone SilentAire device (or third party luminaire by others).
5. Total system wattage is project and product specific, per the compatible ETi SSL or third party luminaire to be specified and field installed.



## MISCELLANEOUS PRODUCT SPECS & DETAILS

### Load Information

<b>Sound Rating</b>	34 dBA
<b>Low Temp Fan</b>	-10° C (14° F)
<b>Unit Weight</b>	1.7 lbs

### Lumen Maintenance

Ambient Temp	TM-21 LM Maintenance (54,000 hours)
25° C (77° F)	TBD

Ambient Temp	TM-21 Theoretical (L70 hours)
25° C (77° F)	TBD

## PLASMA & FAN SPECS AND DETAILS

<b>Air Flow Rate</b>	10.0 CFM
<b>Fan Sound Rating</b>	34 dBA
<b>Fan Wattage</b>	1.0
<b>Fan Lifetime</b>	50,000 hrs

## PLASMA UNIVERSAL FLUSHMOUNT OVERVIEW

The Plasma Universal Flushmount is a hybrid lighting solution that combines traditional LED ambient illumination with new Plasma Technology. No specialized controls, safety measures or training required. Plasma products are 100% 'People Safe' when in use while the space is occupied vs. direct UVC solutions that can be a health and safety risk if not properly operated.

The second generation of Blue Halo utilizes nonthermal "cold" plasma. Our new luminaires will use an internal fan system to push and disperse plasma from our PATENT PENDING Proprietary Technology filling the space with positive and negative ions neutralizing harmful pathogens, pollutants and even odors. Blue Halo's Plasma Technology continually and proactively treats the air in the occupied space at the source of contamination.



1. Nonthermal "cold" plasma is generated internally via our Patent Pending Proprietary Technology.
2. Internal circulation system pushes and disperses plasma from the plasma generator.
3. The space is filled with positive and negative ions neutralizing harmful pathogens, pollutants, and even odors.
4. Plasma technology continually and proactively treats the air in the occupied space at the source of contamination.

## PLASMA TECHNOLOGY DETAILS

- Plasma is one of the four fundamental states of matter.
- A plasma is an electrically charged gas into which sufficient energy is provided to free electrons from atoms or molecules and to allow both species, ions and electrons, to coexist.
- A plasma is created when one or more electrons are torn free from an atom. Atoms that are missing electrons are called "ions". Ions have a positive electrical charge.
- A plasma is generally a mix of these positively charged ions and negatively charged electrons.
- Plasma occurs naturally on Earth from flames, lightning and the Aurora Borealis.
- Plasma is proven method in the medical field for disinfection/sterilization of medical devices, as well as the degradation of toxins and other pathological contaminants.
- Wide-ranging applications of Plasma Technology make it 100% safe in all occupied spaces.

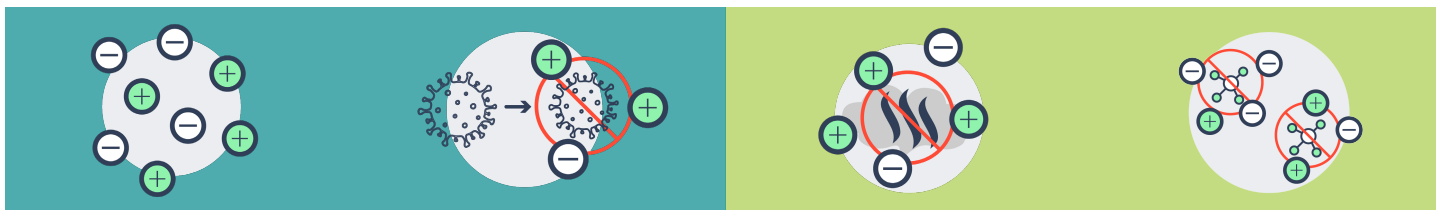

Airborne particles are charged by the ions released by the plasma generator causing them to cluster and easily be caught in the air.

This ionized air that contains positively and negatively charged molecules attract and kill germs on contact.

Odorous gases and aerosols oxidize on contact with ions and are neutralized as well.

Ions cause a chemical reaction with VOCs breaking down their molecular structure.